

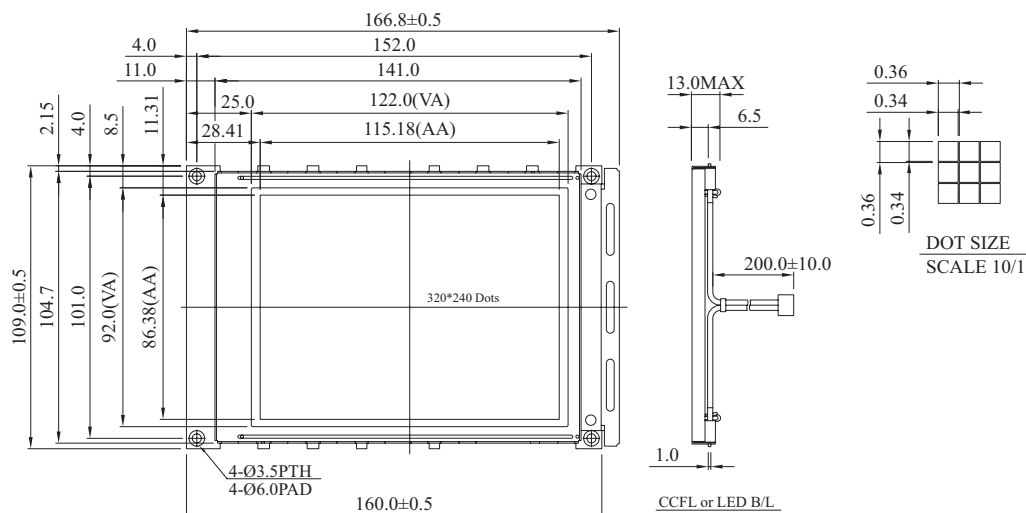

WG320240BX/BP2/BP3 Graphic 320x240 dots

Dimension drawing



Feature

1. Built-in controller Epson-S1D13700
2. Built-in Negative Voltage generator
3. 1/240 duty cycle
4. Touch screen option
5. Temperature compensation option
6. BP2: DIP connection
7. BP3: touch panel driver

Pin NO.	Symbol	Function
1	Vss	Ground
2	Vdd	Power supply for logic
3	Vo	Driving voltage for LCD
4	Ao	RD=L, WR=H, AO=L: Date Read AO=H: Status read RD=H, WR=L, AO=L: Date Write AO=H: Command write
5	WR	8080 family: Write signal, 6800 family: R/W signal
6	RD	8080 family: Read signal, 6800 family: Enable clock
7	DB0	Data bus line
8	DB1	Data bus line
9	DB2	Data bus line
10	DB3	Data bus line
11	DB4	Data bus line
12	DB5	Data bus line
13	DB6	Data bus line
14	DB7	Data bus line
15	CS	Chip select, Active L
16	RES	Controller reset signal, Active L
17	Vee	Negative Voltage Output
18	SEL	8088 or 6800 interface selection (1:68, 0:80)
19	FG	Frame Ground
20	WAIT	Check Busy

Mechanical Data

Item	Standard Value	Unit
Module Dimension	166.8x109.0	mm
Viewing Area	122.0x92.0	mm
Mounting hole	152.0x101.0	mm
Dot Pitch	0.36x0.36	mm

Absolute Maximum Rating

Item	Symbol	Standard Value			Unit
		min.	typ.	max.	
Power Supply	VDD-VSS	4.5	5.0	5.5	V
Input Voltage	VI	0	---	VDD	V

Note: VSS=0 Volt, VDD=5.0 Volt.

Electronical Characteristics

Item	Symbol	Condition	Standard Value			Unit
			min.	typ.	max.	
Input Voltage	VDD	---	4.75	5.0	5.25	V
Supply Current	IDD	VDD=5V	65.0	75.0	85.0	mA
Recommended LC Driving Voltage for Normal Temp. Version module	VDD-V0	-20°C	---	---	26.1	V
		25°C	---	23.8	---	
		70°C	22.2	---	---	
CCFL Starting Voltage	VFLS	25°C	---	600	---	Vrms
CCFL Driving Voltage	VFLD	25°C	---	270	---	Vrms
CCFL Driving Current	IFLD	VFO=450Vrms 30KHz	4.8	5.3	5.5	mA
LED Forward Voltage	VF	25°C	3.4	3.5	3.6	V
LED Forward Current	IF	25°C	140	160	180	mA
EL Power Supply Current	IEF	Vel=110VAC, 400Hz	---	---	5.0	mA

Graphic type