

TA3 TA4 Series

Tact Switches

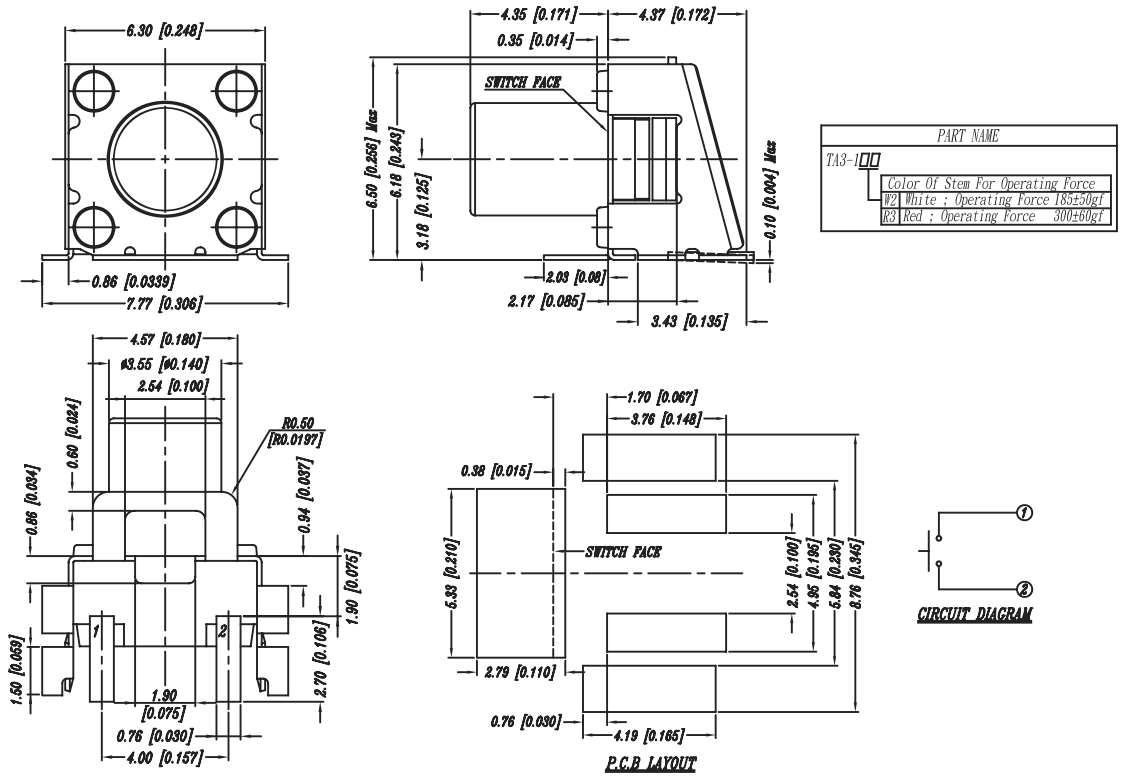

TA3-1W2-V



NOTE:
1. ALL DIMENSIONS ARE IN MILLIMETERS, BRACKETED DIMENSIONS ARE IN INCHES.
2. GENERAL TOLERANCES MAX. ±0.20mm.



TA4-58G1

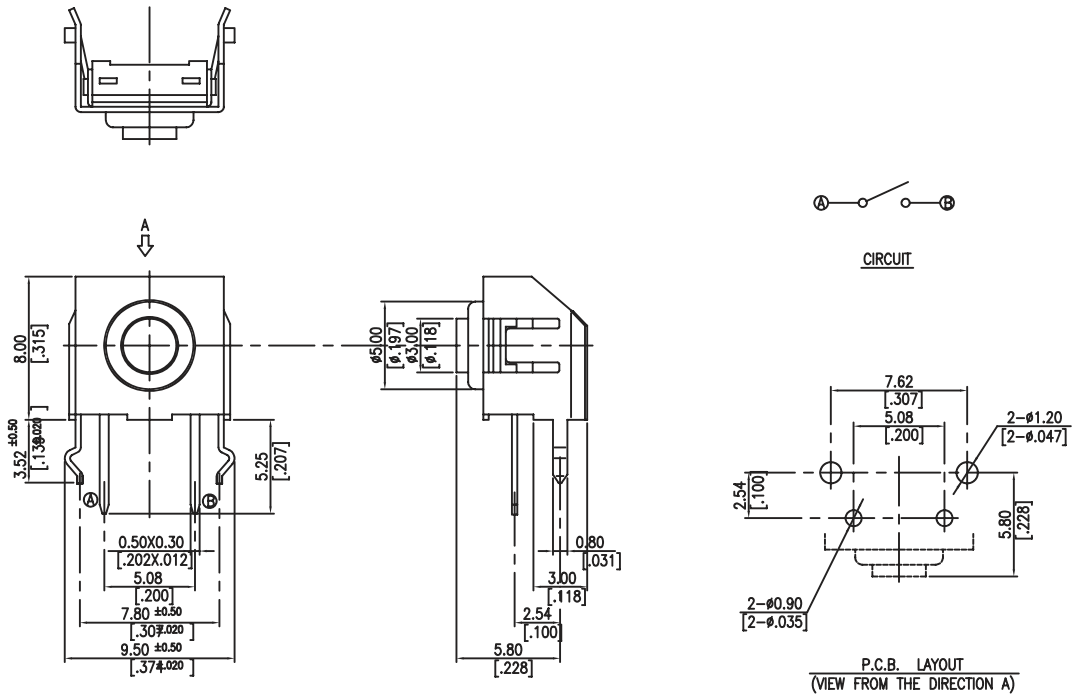

NOTE:
1. ALL DIMENSIONS ARE IN MILLIMETERS. BRACKETED DIMENSIONS ARE IN INCHES.
2. GENERAL TOLERANCES ±0.2mm.