

# 1F Series

## Miniature Toggle Switches

1F Miniature Toggle Switches



### SPECIFICATIONS

**CONTACT RATING:** AC 125V 6A, AC 250V 3A ,DC 30V 3A  
**MECHANICAL LIFE:** 200,000 make-and-break cycles DC 10V & 0.1mA.  
**CONTACT RESISTANCE:** 10mΩ MAX.  
**INSULATION RESISTANCE:** 500V 500MΩ MIN.  
**DIELECTRIC STRENGTH:** 1,000 V RMS@sea level.  
**OPERATING TEMPERATURE:** -30° C to 85° C.  
**WATER-RESISTANCE:** 100 MAKE-AND-BREK CYCLES MIN AT10cmDEPTH

### MATERIALS

**CASE:** Diallyl phthalate (DAP) (UL94v-0).  
**ACTUATOR:** Brass,chrome plated.  
**BUSHING:** Brass,nickel plated.  
**HOUSING:** Stainless Steel.  
**SWITCH SUPPORT:** Brass,tin plated.  
**TERMINAL/CONTACT:**Silver or gold plated. (See Page 25)

### HOW TO ORDER

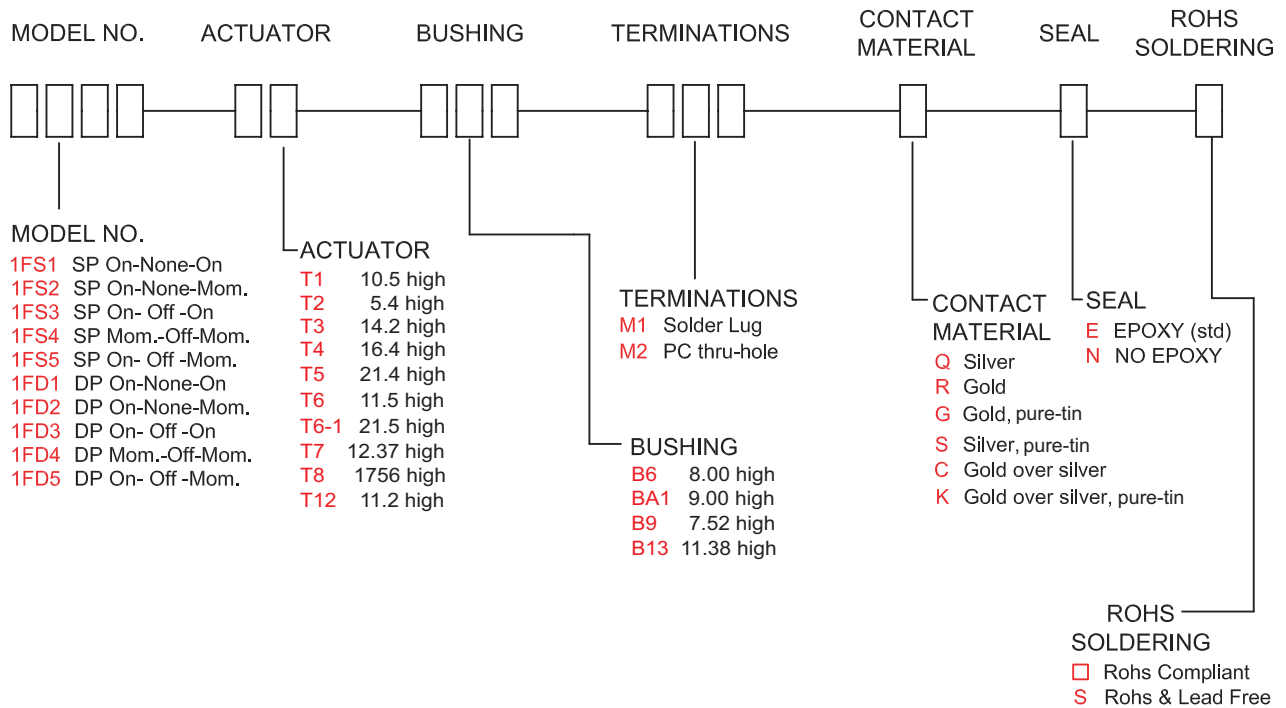

Crest Technologies Pty Ltd. www.cresttech.com.au sales@cresttech.com.au +61 3 9873 8830

### SWITCH FUNCTION

NO. POLES	MODEL NO.	SWITCH FUNCTION			CONNECTED TERMINALS / SCHEMATIC		
		POS.1	POS.2	POS.3	POS.1	POS.2	POS.3
SP	1FS1	ON	NONE	ON	2-3 	N/A	2-1 
	1FS2	ON	NONE	MOM			
	1FS3	ON	OFF	ON			
	1FS4	MOM	OFF	MOM			
	1FS5	ON	OFF	MOM			
DP	1FD1	ON	NONE	ON	2-3,5-6 	N/A	2-1,5-4 
	1FD2	ON	NONE	MOM			
	1FD3	ON	OFF	ON			
	1FD4	MOM	OFF	MOM			
	1FD5	ON	OFF	MOM			

MOM=MOMENTARY

### ACTUATOR OPTIONS

T1 STD

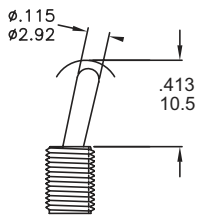

T2

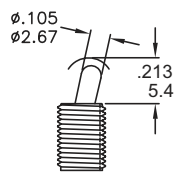

T3

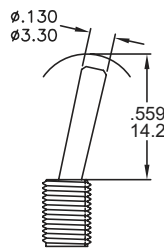

T4

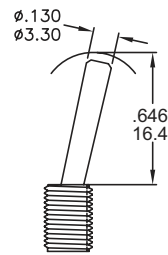

T5

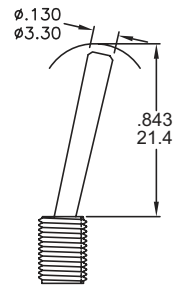

T6 FLATTED WITH ANTIROTATION

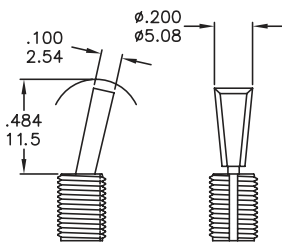

T6-1

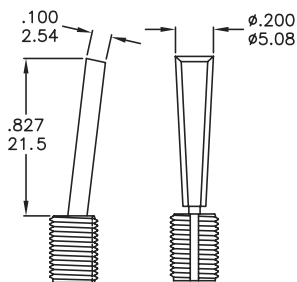

T7

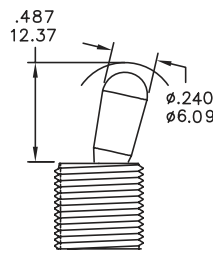

T8

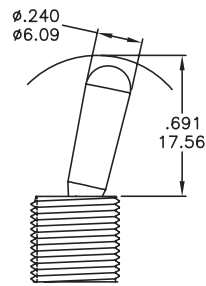

T12

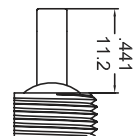

T6.T6-1 use with B6 bushing only

T7.T8 use with B13 bushing only

T12 use with BA1 bushing only

### BUSHING OPTIONS

#### B6 HIGH TORQUE

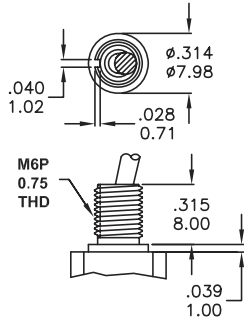

#### BA1 SPLASH PROOF

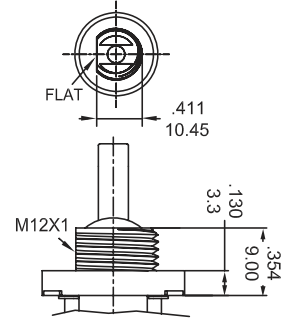

Use with T12 actuators only  
BA1 Bear Strength from top of actuator up to 10kg aside up to 15kg

#### B9 SPLASH PROOF

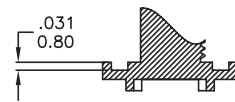
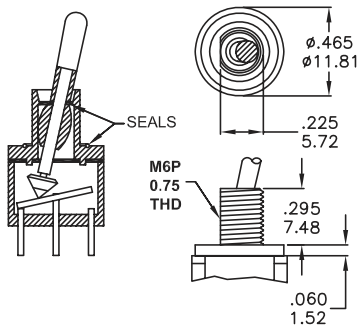

#### CP-1TEB

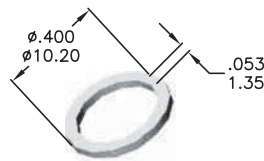

O-ring supplied with B9 bushing

#### B13

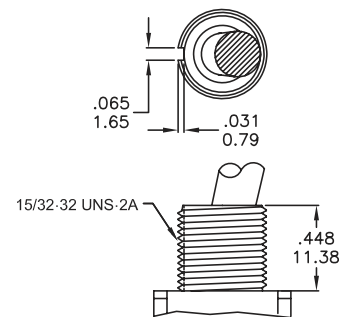

### TERMINATION OPTIONS

#### M1 SOLDER LUG

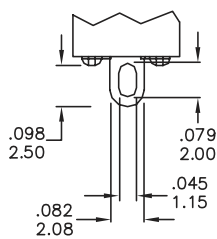

#### M2 PC THRU-HOLE

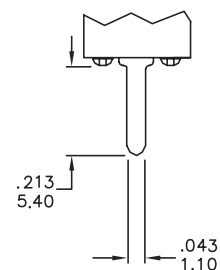

### POLE OPTIONS

#### SPDT

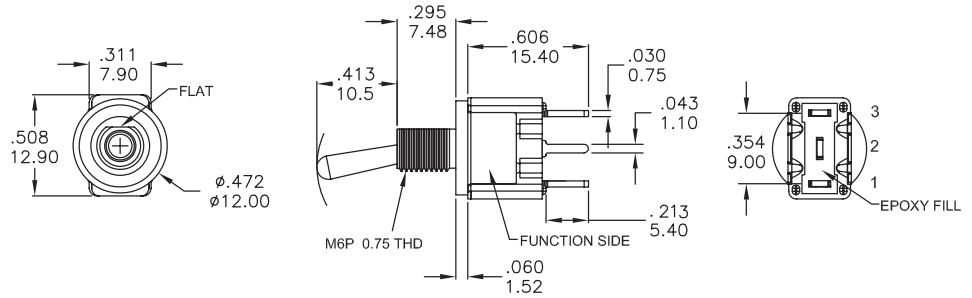

Part No. Shown: 1FS1T1B9M2QES

#### DPDT

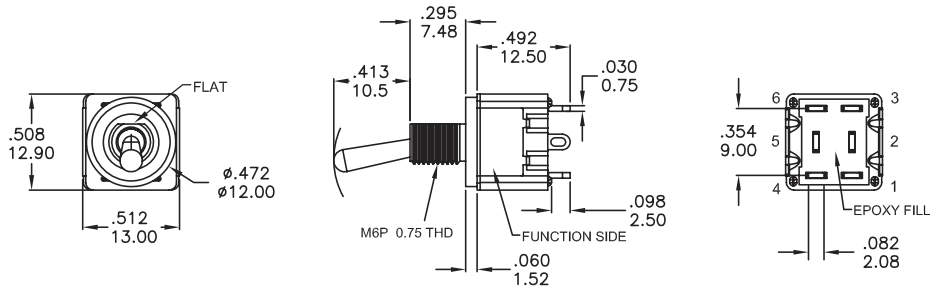

Part No. Shown: 1FD1T1B9M1QES

#### SPDT

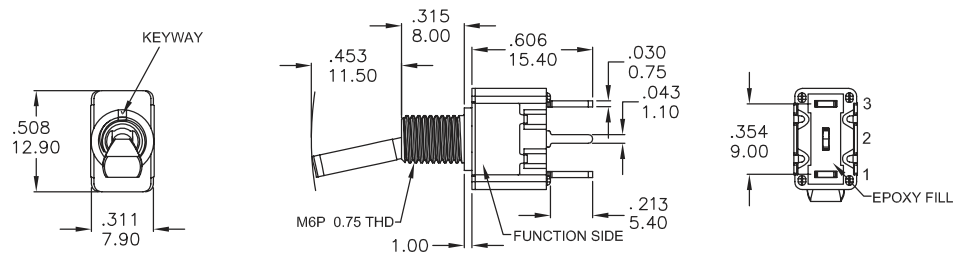

Part No. Shown: 1FS1T6B6M2QES

#### DPDT

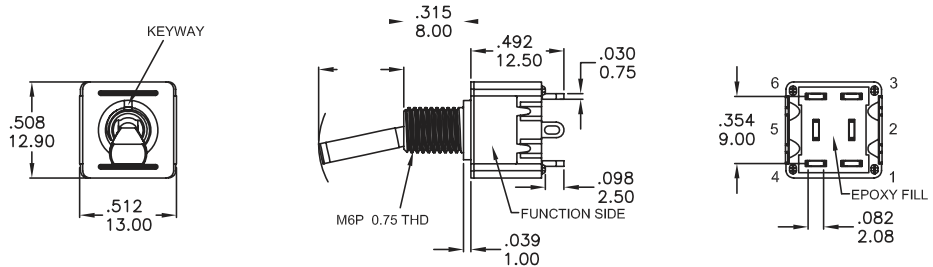

Part No. Shown: 1FD1T6B6M1QES

SPDT

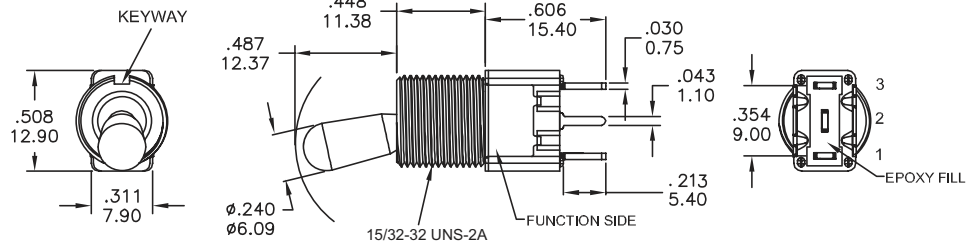

Part No. Shown: 1FS1T7B13M1QES

DPDT

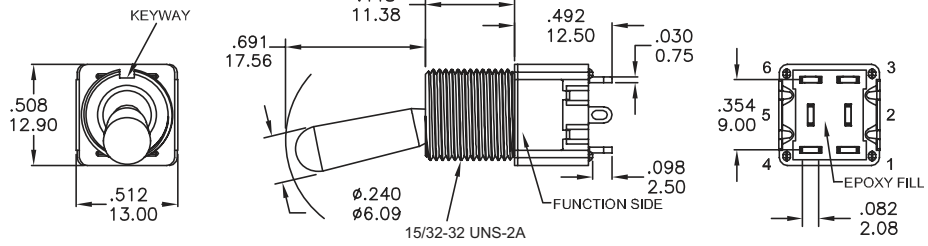

Part No. Shown: 1FD1T8B13M1QES

SPDT

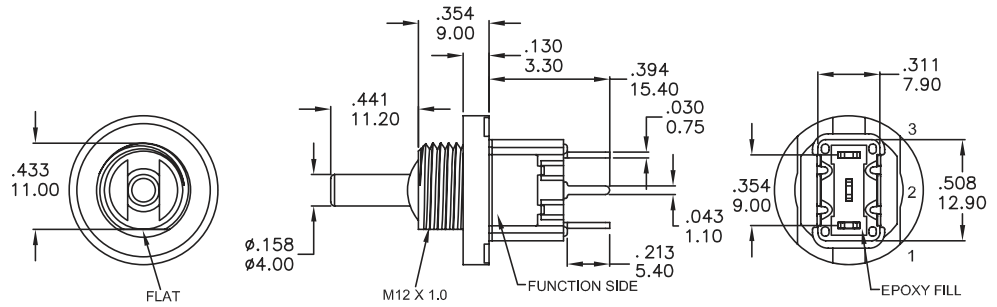

Part No. Shown: 1FS1T12BA1M2QES

DPDT

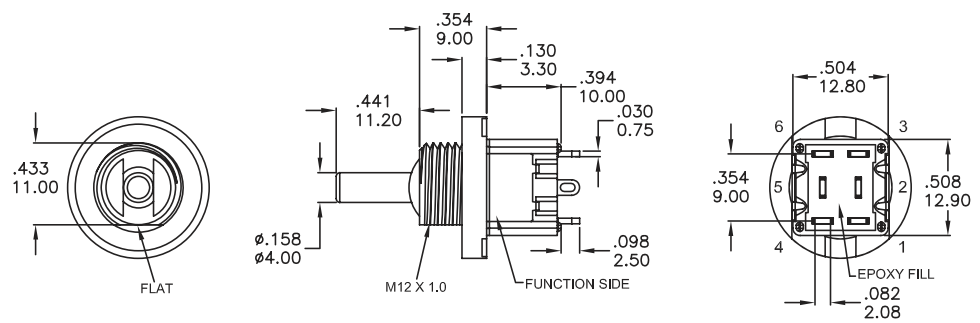

Part No. Shown: 1FD1T12BA1M1QES

### CONTACT MATERIAL OPTIONS

	CONTACT MATERIAL	TERMINATION RATING	RATINGS
<b>Q</b>	<b>Silver</b>	<b>Q</b> = Silver	6 Amps with resistant load @ 125VAC or 28VDC 3 Amps with resistant load @ 250VAC
<b>S</b>		<b>S</b> = Silver,pure - tin	
<b>C</b>	<b>Gold over Silver</b>	<b>C</b> = Gold over silver	
<b>K</b>		<b>K</b> = Gold over silver,pure - tin	
<b>R</b>	<b>Gold</b>	<b>R</b> = Gold	0.4 Volt-Amps(VA)max. @ 20V max. (AC or DC)
<b>G</b>		<b>G</b> = Gold,pure - tin	



### SOLDERING PROCESSES

**MANUAL SOLDERING** : Use soldering iron of 30 watts, controlled at 350°C approximately 5 seconds while applying solder.

**WAVE SOLDERING** : Recommended Soldering Temperature:260±5°C  
Duration of Solder Immersion: 5 ±1 seconds  
(PCB is 1.6mm in thickness)

**SOLDERING** : Vapor phase

### Temperature Profile

Zone	Room temperature	Time ( Sec )
Pre-heat ( A )	150°C	Min 120s
Soak ( B )	180°C~200°C	Min 150s
Peak ( C )	200°C~235°C	Min 30s
Peak ( D )	235°C~260°C	Min 40s
Peak ( E )	260°C	Max 10s

