

# Equipment Feet

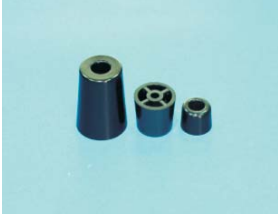

- MATERIAL:ABS
- COLOR:BLACK
- UNIT: mm

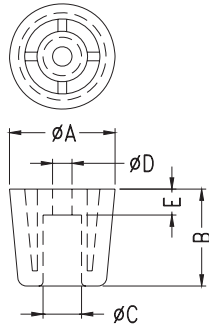

PART NO	A	B	C	D	E	PACKAGE
YPFFCT-1	15.0	8.0	7.5	3.7	3.5	1000
YPFFCT-2	20.0	12.1	8.2	4.1	5.5	500
YPFFCT-3	25.1	16.2	10.4	4.3	8.1	100
YPFFCT-4	24.4	22.4	8.9	4.6	6.0	
YPFFCT-5	26.0	12.7	10.9	5.1	5.7	
YPFFCT-6	22.5	22.4	8.6	4.6	6.0	
YPFFCT-7	17.0	17.0	7.5	3.2	6.0	

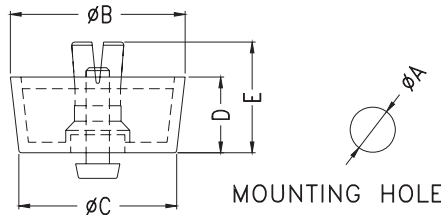

- MATERIAL:=P.E
- MATERIAL: \* =TPR
- PIN MATERIAL:P.P
- COLOR:BLACK/GRAY/COMPUTER
- UNIT: mm

PART NO	A	B	C	D	E	CHASSIS THICKNESS	PACKAGE
* YPFFC-1	8.0	20.8	19.8	6.4	11.8	1.0~2.5	500
YPFFC-2	8.0	20.0	18.0	10.0	15.4	1.0~2.5	
* YPFFC-3	8.0	23.7	19.5	13.7	19.2	1.0~2.5	250
* YPFFC-4	8.0	25.0	23.5	6.5	12.5	1.0~2.5	500
* YPFFC-5	8.0	30.0	27.7	12.8	18.8	1.0~2.5	200
* YPFFC-6	10.0	28.5	26.5	8.2	14.0	1.0~3.5	250
YPFFC-7	5.0	12.7	12.0	4.4	8.5	1.0~2.0	1000
YPFFC-8	5.0	15.7	15.0	4.4	8.5	1.0~2.0	
YPFFC-9	8.0	20.0	18.6	4.0	7.0	1.0~2.0	
YPFFC-10	8.0	23.8	22.0	5.0	10.0	1.0~2.5	500
YPFFC-11	10.0	31.5	28.5	7.8	13.6	1.0~3.5	
YPFFC-12	8.0	20.0	18.0	15.0	20.8	1.0~3.0	250
YPFFC-13	8.0	20.0	18.0	18.0	24.3	0.8~1.0	
YPFFC-14	8.0	19.5	18.7	5.0	10.5	0.8~2.0	
YPFFC-16	10.0	29.4	26.5	15.0	23.0	1.0~3.5	100
YPFFC-21	8.0	20.0	19.3	20.5	25.6	0.8~2.0	250
YPFFC-22	8.0	19.2	17.2	7.9	12.1	0.8~1.2	500
YPFFC-24	8.0	23.0	21.0	8.0	13.3	0.8~2.0	250
YPFFC-25	8.0	24.0	20.0	10.5	15.8	0.8~2.0	
* YPFFC-26	8.0	22.0	21.0	3.5	10.5	1.0~3.0	500
* YPFFC-27	8.0	26.7	24.8	16.0	21.0	1.0~3.0	250
* YPFFC-28	8.0	20.0	18.0	10.5	14.0	0.8~2.0	

# Equipment Feet

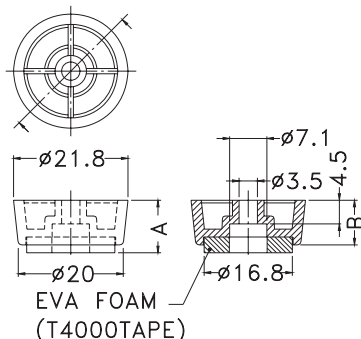

PART NO.	A	B	PACKAGE
YPFFCS-1	10.0	8.5	500
YPFFCS-2	15.0	13.5	

- MATERIAL:ABS
- COLOR:BLACK
- UNIT: mm

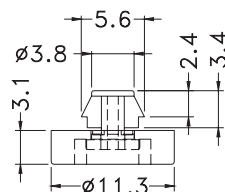

PART NO	PACKAGE
YPFFC-15	1000

- MATERIAL:TPE
- PIN MATERIAL:NYLON 66 UL94V-2
- COLOR:BLACK
- UNIT: mm

HOLE IN CHASSIS:  $\phi 4.0$   
 CHASSIS THICKNESS: 0.8~1.0

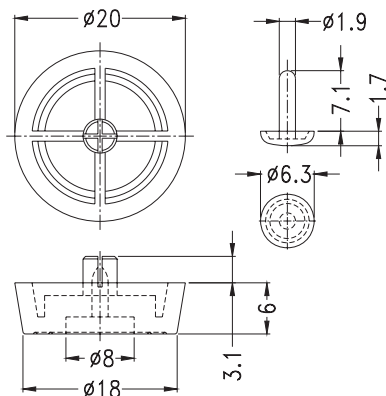
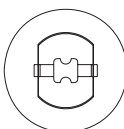

PART NO	PACKAGE
YPFFC-19	100

- FOOT MATERIAL:P.E
- PIN MATERIAL:P.P
- COLOR:BLACK
- UNIT: mm

HOLE IN CHASSIS:  $\phi 4.0$   
 CHASSIS THICKNESS: 0.8

# Equipment Feet

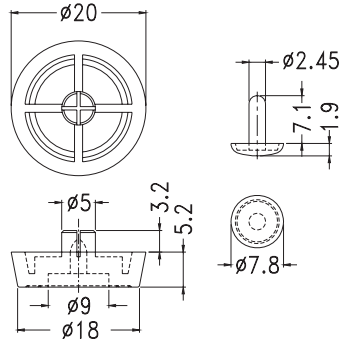

PART NO	PACKAGE
YPFFC-20	100

- FOOT MATERIAL:P.E
- PIN MATERIAL:P.P
- COLOR:BLACK
- UNIT: mm

HOLE IN CHASSIS:Ø5.0  
 CHASSIS THICKNESS:0.8

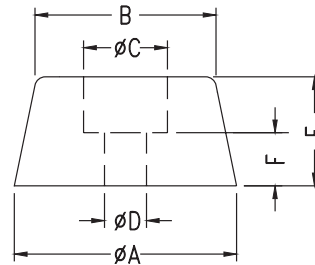

- MATERIAL:P.V.C/RUBBER/P.P
- COLOR:BLACK/WHITE
- UNIT: mm

PART NO	A	B	C	D	E	F	MATERIAL	PACKAGE
YPNFC-001	14.8	8.0	6.0	3.0	7.0	3.1	P.V.C	1000
YPNFC-002	11.5	8.7	5.6	3.2	7.4	3.3	RUBBER	
YPNFC-004	16.0	13.0	6.0	3.0	7.8	4.0	P.V.C	
YPNFC-005	17.2	16.2	9.0	4.0	7.0	3.0		
YPNFC-006	20.2	18.4	10.0	3.0	8.0	4.0	P.V.C	500
YPNFC-007	25.0	21.5	8.5	3.3	5.8	2.8		
YPNFC-008	20.0	15.0	9.8	3.0	10.5	5.0		
YPNFC-008A	20.0	15.0	9.8	4.0	10.5	5.0	P.P	1000
YPNFC-009	11.0	8.8	6.0	3.5	5.7	2.3		
YPNFC-013	18.0	13.7	7.8	3.5	9.8	2.7	P.V.C	100
YPNFC-014	28.0	21.2	9.7	3.8	20.0	6.0	P.V.C	100