

Overview

An audio limiter serves to prevent the signal level from exceeding a preset limit, and as such is often used to protect a following device from overload. These can include recorders (both analog and digital), transmitters and power amplifier/loudspeaker combinations. An ideal limiter introduces very little distortion or noise when it is inactive, and controls the audio level in a way that is pleasing to the ear, while keeping tight control over the output level. **Audiohm** optocouplers offer a cost competitive, high performance solution that fulfills these requirements. They offer the advantage over VCA designs that the active element is essentially only in the circuit (potentially causing distortion) when gain reduction is taking place.

Circuit Description

Figure 1 shows the circuit for a simple limiter with variable threshold, the amplitude response of which is shown in **Figure 2**.

Figure 1

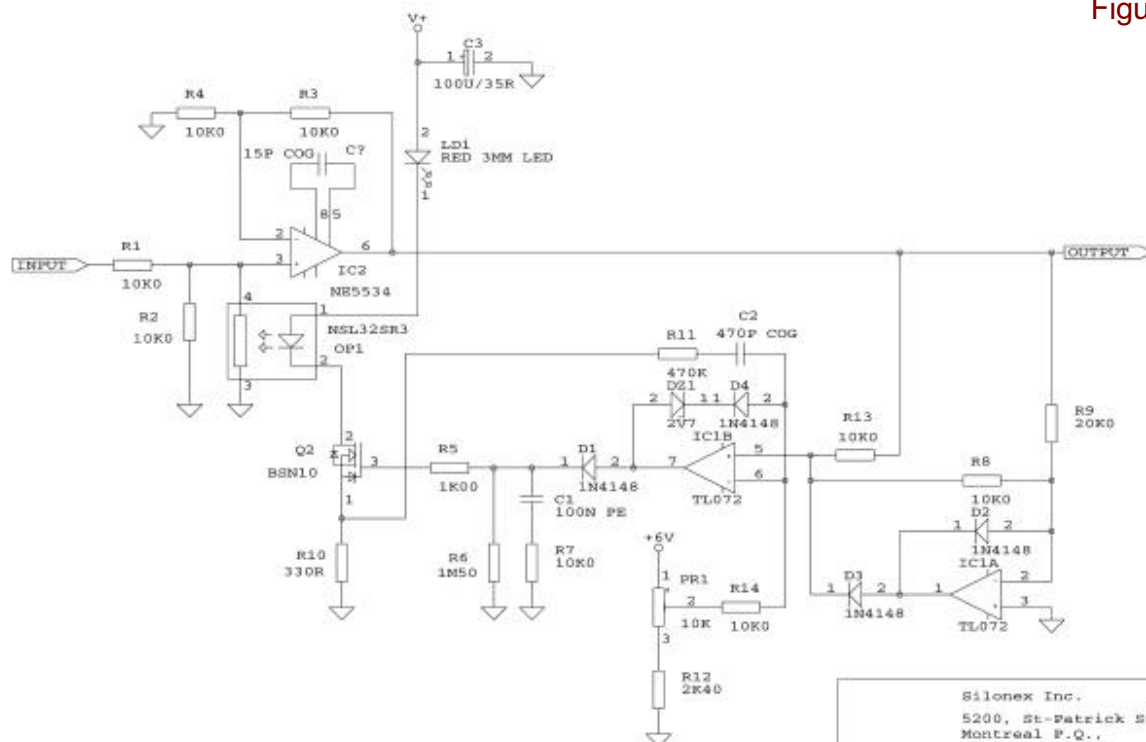

Silonex Inc. 5200, St-Patrick St. Montreal P.Q., Canada H4E 4N9 (514) 768-8000	
Title	SIMPLE OPTOCOUPLER LIMITER
Size	Document Number
A4	LIMITER2.SCH
Date:	March 12, 2001 Sheet 1 of 1

OP1 in conjunction with R1 and R2 form a shunt attenuator which acts as the gain control element, with the output buffered by IC2 to prevent loading effects. The standing attenuation of R1/R2 is corrected by the gain introduced by R3 / R4. The output of IC2 is full wave rectified by IC1A and associated components. The resulting output voltage is then compared with a threshold reference by IC1B, the output of which normally sits at approximately 3.3 V lower. As soon as the circuit output level starts to exceed the threshold reference voltage set on PR1 wiper, IC1B output will rapidly rise, turning on Q1 and in turn OP1 which will limit the output level. With the values shown this limiting occurs between +6 dBu (PR1 counterclockwise) and +16 dBu (PR1 clockwise). For fixed threshold applications PR1 and R14 can be replaced by a voltage divider from the reference voltage as long as the parallel impedance is kept to approximately 12 KΩ. The current flowing through the LED of OP1 also illuminates LD1, to indicate that gain reduction is taking place. C1 serves to smooth out the potentially rapid gain changes that could result in unacceptable distortion, discharging through R6, which sets the release time constant. The optimal value of R6 depends on the nature of the source material. Larger values giving a longer release with less audio distortion, but giving greater susceptibility to “pumping” effects where a prominent transient signal (i.e. a drum beat) instigates more gain reduction than is really necessary. The proper way to determine the best value for your application is with your ears. R7, R11 and C2 give frequency compensation for the best dynamic response. The circuit will run off split supplies of +/- 9 V to +/- 17 V, allowing maximum signal levels of +16 dBu to +22 dBu RMS.

Figure 2

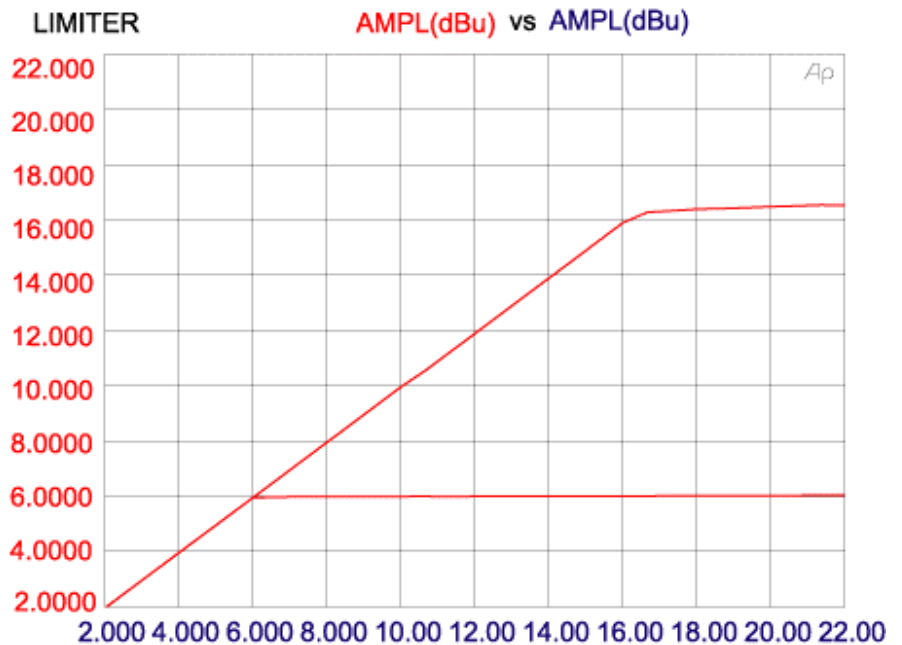

The ideal optocoupler for this application is the **NSL-32SR3**, because of its low distortion, high speed and low drive current. In the circuit shown, distortion below the limiting threshold is typically less than 0.001%, with an output noise level of <= 108 dBu. Distortion while limiting is a function of input frequency, the time constant of C1 / R6 and the amount of gain reduction, typically 0.5% at 1 KHz. Attack time is <100 μsec, which is fast enough to protect most following systems. A standard **NSL-32** can also be used in this circuit with reduced performance, however, R7 should be increased to 27 KΩ to preserve stability.