



### Features

- 6mm Round / Single-Turn / Cermet Industrial / Open Frame
- Cross slot adjustment options
- Horizontal and vertical mounting styles
- Dust resistant / splash resistant covers
- Pc board stand-offs and retention feature
- Front and top adjust styles

## 6mm Ceramic, Trimmer Potentiometer

### Electrical Characteristics

#### Standard Resistance Range

.....100Ω to 1 megohm  
 (see standard resistance table)

Resistance Tolerance.....±20% (TK±25%)

Adjustment Angle.....240° ± 20°

Residual Resistance.....=<500Ω, 10Ω > 500Ω, 2% (TK=<1KΩ, 20Ω >1KΩ, 5%)

### Environmental Characteristics

Power Rating

Max Working Voltage.....100V

70°C.....0.3 Watt (TK 0.1 Watt)

Temperature Range.....-30°C to +85°C (TK -10°C to +70°C)

Temperature Coefficient.....±250ppm/°C (TK±1000ppm/°C)

Rotation Life.....±10% (TK±15%)

Load Life.....500 hours 0.3 watt 70°C ±5% (TK 240 hours 0.1 watt 50°C + 5% - 20%)

### Physical Characteristics

Torque (Operating).....30~300 gf-cm

Stop Strength.....0.5 kgf-cm

Soldering Conditions.....240°C to 260°C  
 and with in 3 seconds

Marking.....Resistance code

Standard Packaging.....500 pcs. Per bag

Aqueous cleaning not recommended

### How to order

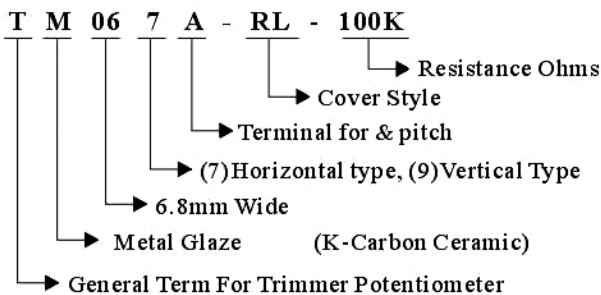

Standard Resistance Table

Resistance Ohms	Resistance Code
100Ω	12
500Ω	52
1KΩ	13
10KΩ	14
1MΩ	16
220Ω	221
2.2KΩ	222
220KΩ	224

## 6mm Ceramic, Trimmer Potentiometer

**STYLE: TM067A-RL  
TK067A-RL**

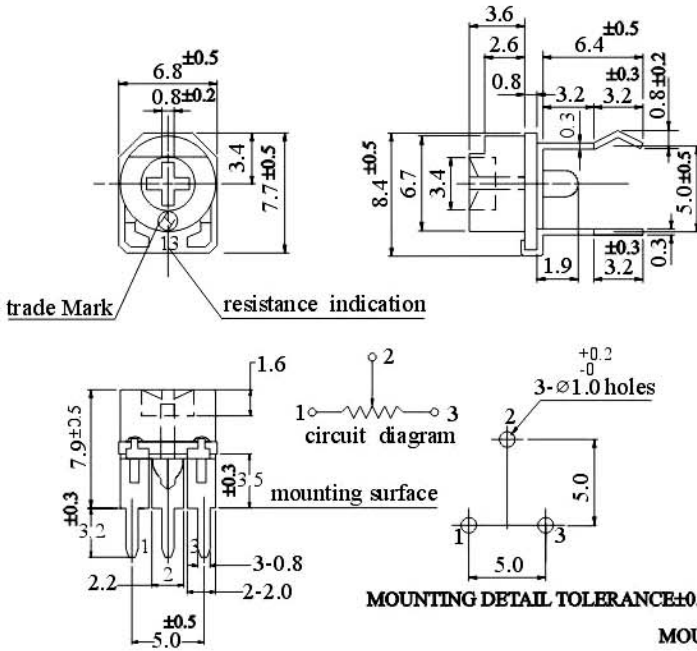

**STYLE: TM069A-RL  
TK069A-RL**

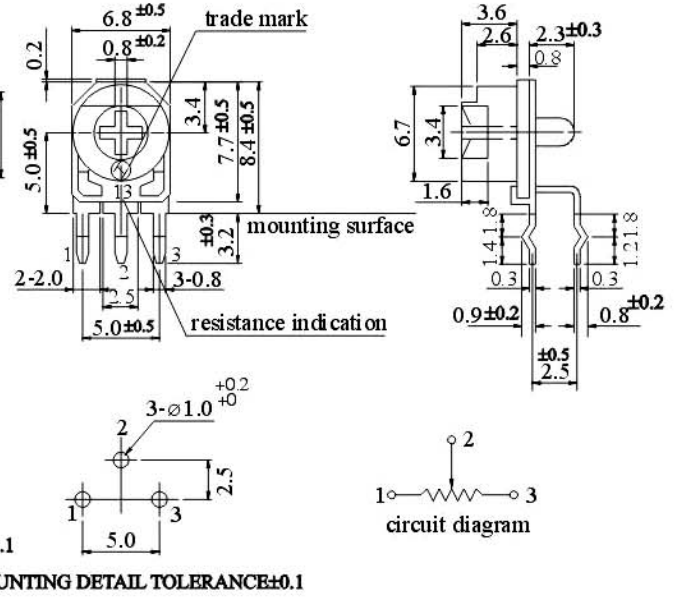

**STYLE : TM069E-RL  
TK069E-RL**

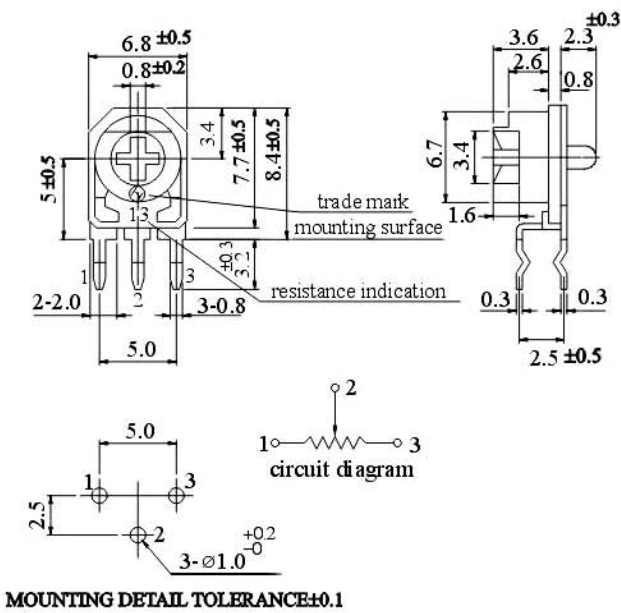

**STYLE : TM066F-0  
TK066F-0**

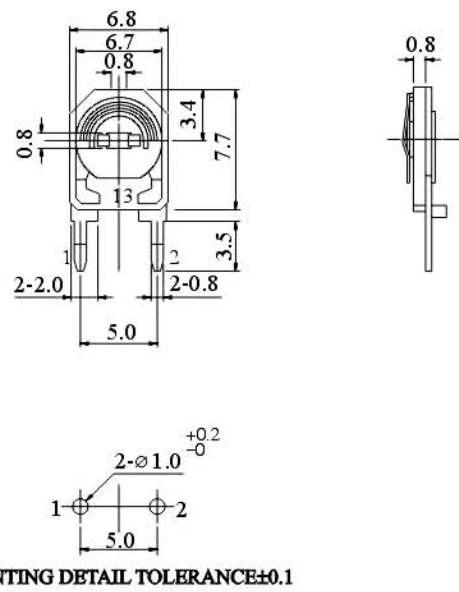

## 6mm Ceramic, Trimmer Potentiometer

**STYLE: TM067A-0  
TK067A-0**

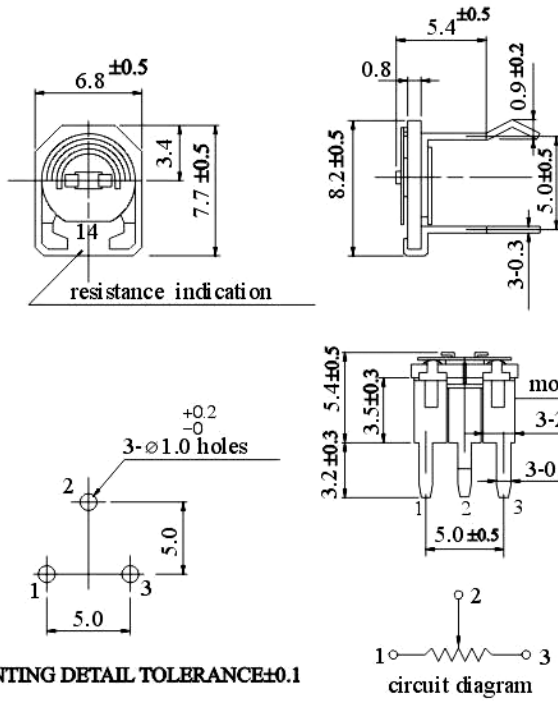

**STYLE: TM069A-0  
TK069A-0**

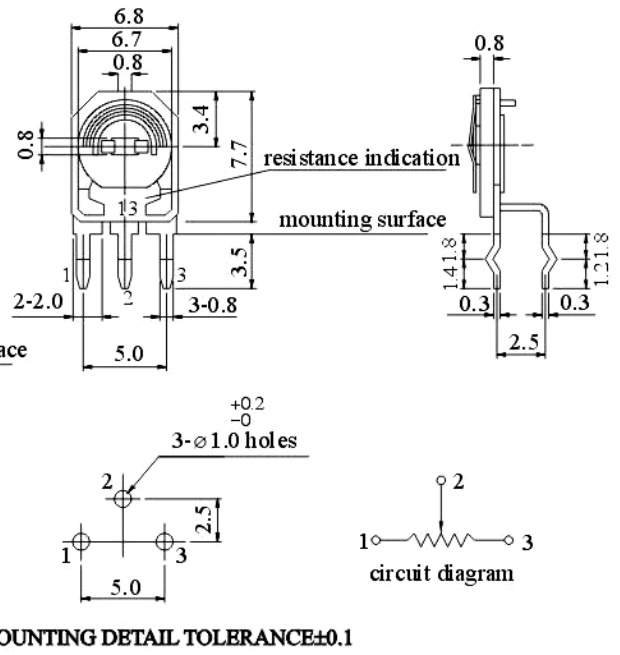

**STYLE : TM069E-0  
TK069E-0**

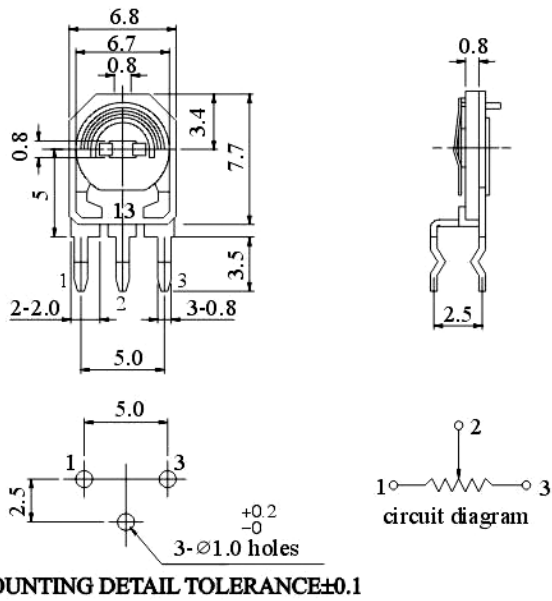

**STYLE : TM067F-0  
TK067F-0**

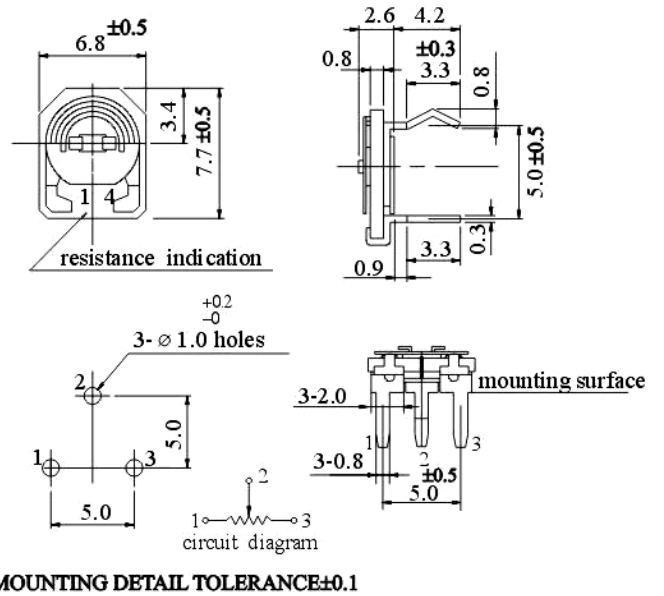

# 6mm Ceramic, Trimmer Potentiometer

STYLE: TM067C-RL  
TK067C-RL

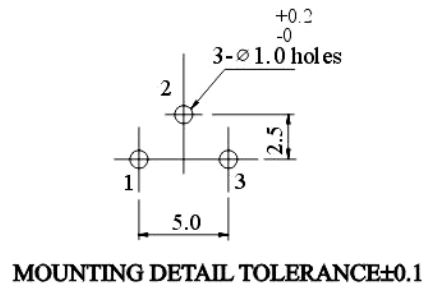
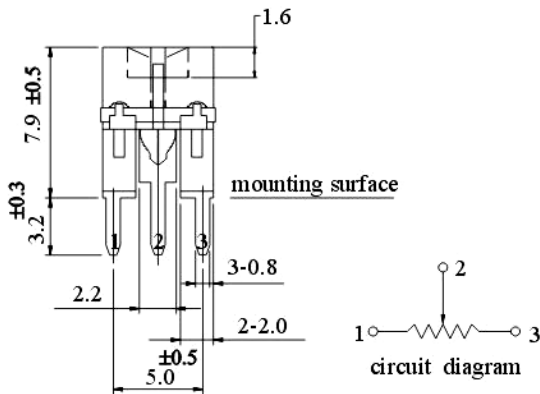
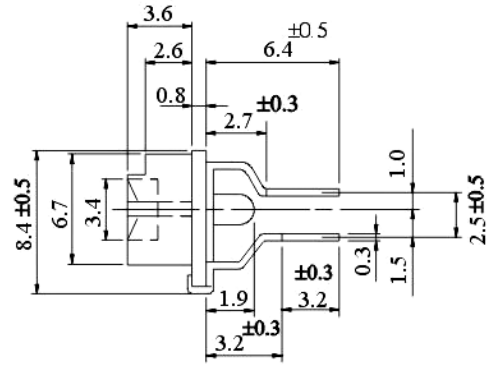
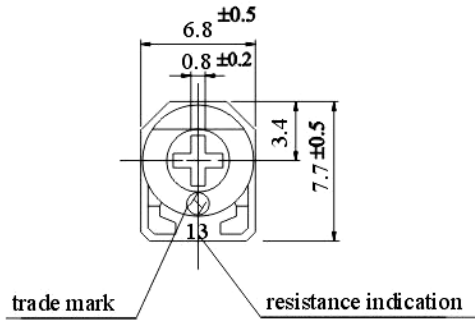

STYLE : TM067D-RL  
TK067D-RL

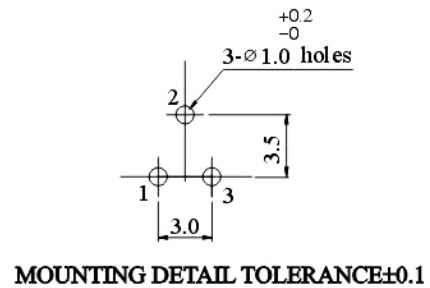
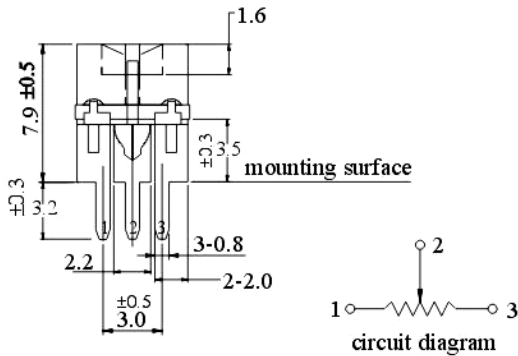
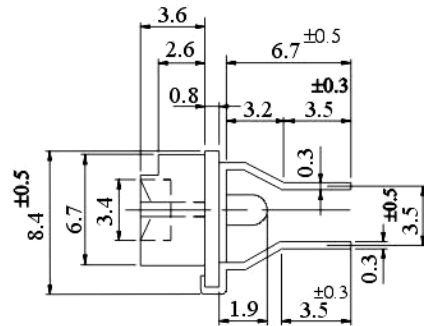
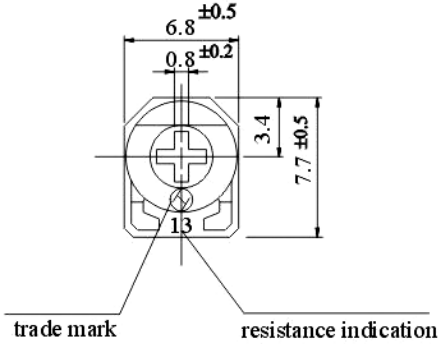

Crest Technologies Pty Ltd  
46/41-49 Norcal Rd Nunawading 3131 Australia  
Tel: (03) 9873 8830 Fax: (03) 9873 8799  
Email: sales@cresttech.com.au  
Web: <http://www.cresttech.com.au>