

DATA SHEET

PART NO. : L-S715W

REV : A / 1

CUSTOMER'S APPROVAL : _____

DCC : _____

DRAWING NO. : DS-31-04-0005

DATE : 2004-03-12

Page : 1

2.8×1.2×0.75mm SIDE VIEW LED WITH REFLECTOR

L-S715W

REV:A / 1

PACKAGE DIMENSIONS

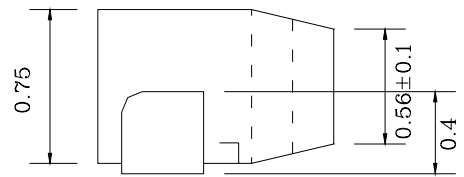
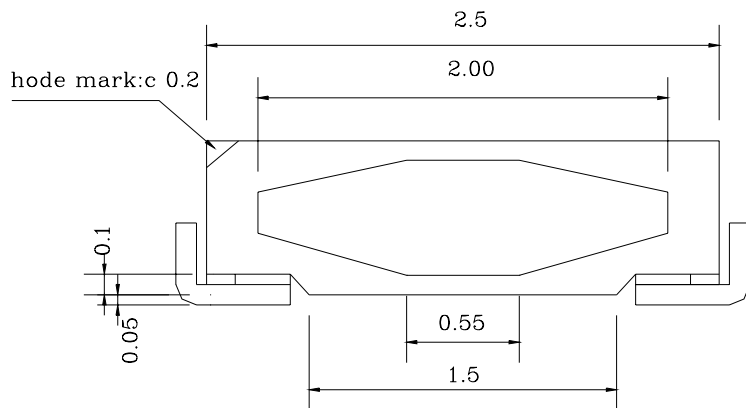

Note:

- 1.All Dimensions are in millimeters.
- 2.Tolerance is $\pm 0.10\text{mm}$ (0.004 ") Unless otherwise specified.
- 3.Lead spacing is measured where the leads emerge from the package.
- 4.Specification are subject to change without notice
- 5.Static Electricity and surge damages the LED. It is recommend use a wrist band or anti-electrostatic glove when handling the LED. All devices, equipment and machinery must be properly grounded

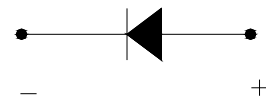
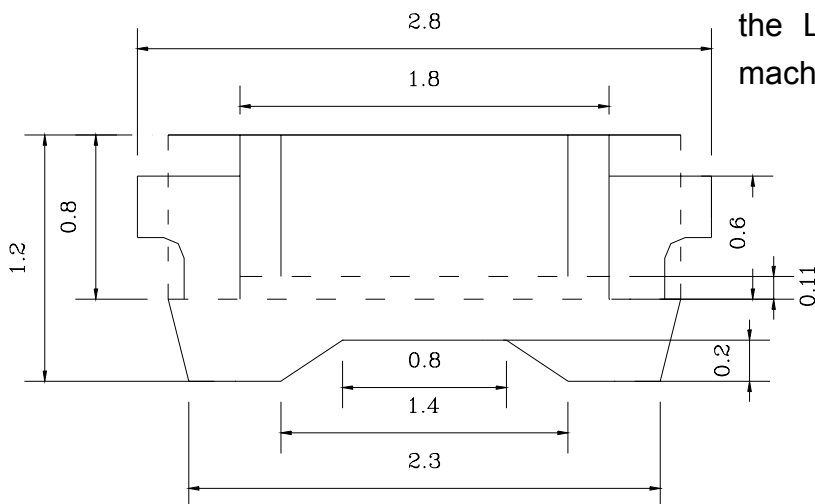

2.8×1.2×0.75mm SIDE VIEW LED WITH REFLECTOR

L-S715W

REV:A / 1

FEATURES

- * High intensity with small package, ideal for backlighting
- * Wide viewing angle(115°)
- * Package Outline (L×W×H)= 2.8×1.2×0.75mm
- * Technology : InGaN
- * Color coordinates CIE(x,y): (0.31,0.31)according to CIE 1931.
- * Suitable for all SMT assembly methods
- * Suitable for all soldering methods
- * Delivery on 8mm tape reels

APPLICATIONS

- * Automotive: indoor lighting.
- * Signal and symbol lightings
- * Backlighting (mobile phones, displays, PDA, Digital Camera.....)
- * All applications in notice high intensities are required

ABSOLUTE MAXIMUM RATING:(Ta=25°C)

SYMBOL	DESCRIPTION	ULTRA WHITE	UNIT
PD	Power Dissipation	114	mW
VR	Reverse Voltage	5	V
IF	Average Forward Current	30	mA
-	Derating Linear From 25°C	0.4	mA/°C
Topr	Operating Temperature Range	-30°C to 85°C	
Tstg	Storage Temperature Range	-40°C to 100°C	

ELECTRO-OPTICAL CHARACTERISTICS:(Ta=25°C)

SYMBOL	DESCRIPTION	TEST CONDITION	MIN.	TYP.	MAX.	UNIT	
VF	Forward Voltage	IF = 20mA	-	3.4	3.8	V	
IR	Reverse Current	VR = 5V			50	μA	
2θ 1/2	Half Intensity Angle	IF = 20mA		115		deg	
IV	Luminous Intensity	IF = 20mA	R	360		500	mcd
			S	500		700	mcd
			T	700		1000	mcd
X	Chromaticity Coordinates	IF = 20mA		0.31			
Y		IF = 20mA		0.31			

2.8×1.2×0.75mm SIDE VIEW LED WITH REFLECTOR**L-S715W****REV:A / 1**

ITEM	MATERIALS
Package	Heat-Resistant Polymer
Encapsulating	Heat Resistance Resin
Electrodes	Ag Plating Copper Alloy

Type	Color of Emission	Color of the Light Emitting Area	Luminous intensity I_v(mcd) IF=20mA
L-S715W	White	Colored	360~1000

2.8×1.2×0.75mm SIDE VIEW LED WITH REFLECTOR

L-S715W

REV:A / 1

Luminous intensity groups:

Luminous intensity group	Measurement condition	Luminous intensity I _v (mcd)
T	I _F =20mA	700 ~ 1000
S		500 ~ 700
R		360 ~ 500

* Luminous intensity group includes 3 groups R to T

* Luminous intensity is tested at a current pulse duration of 25ms and a tolerance of $\pm 10\%$

Chromaticity Coordinates Ranks:

Rank	X	Y	Rank	X	Y
A0	0.257	0.275	C0	0.300	0.330
	0.273	0.236		0.311	0.287
	0.291	0.265		0.330	0.310
	0.280	0.305		0.320	0.350
B0	0.280	0.305	D0	0.320	0.350
	0.291	0.265		0.330	0.310
	0.311	0.287		0.350	0.335
	0.300	0.330		0.350	0.370

*Color rank is tested at a current pulse duration of 25ms and a tolerance of the chromaticity coordinate of ± 0.01

Forward voltage:

V1		V2		V3		V4	
3.00V	3.20V	3.20V	3.40V	3.40V	3.60V	3.60V	3.80V

2.8×1.2×0.75mm SIDE VIEW LED WITH REFLECTOR

L-S715W

REV:A / 1

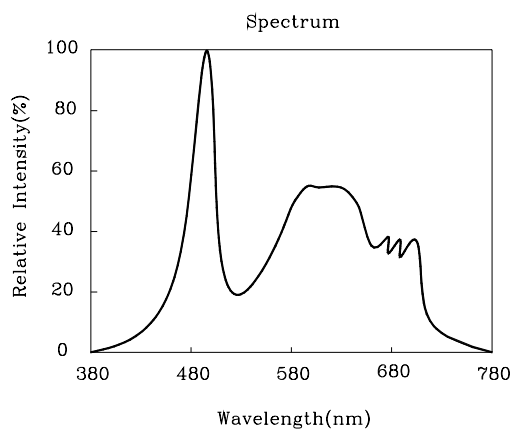
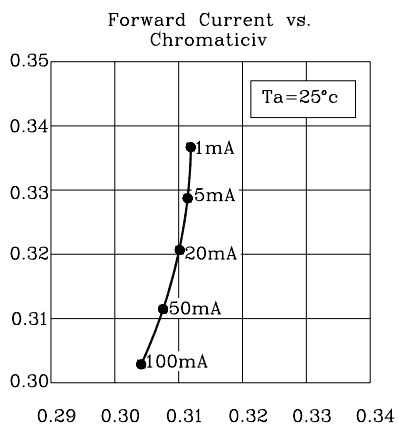
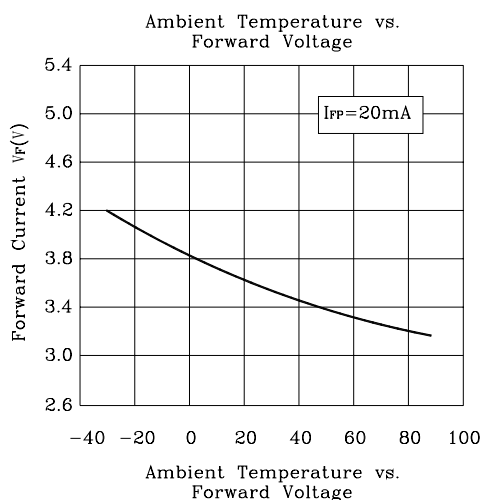
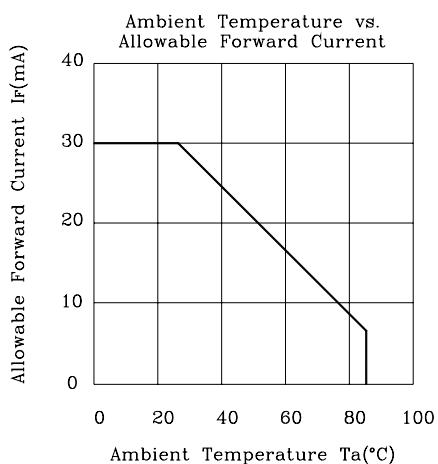
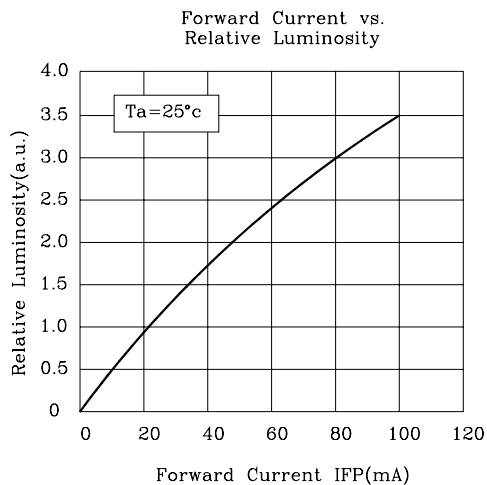
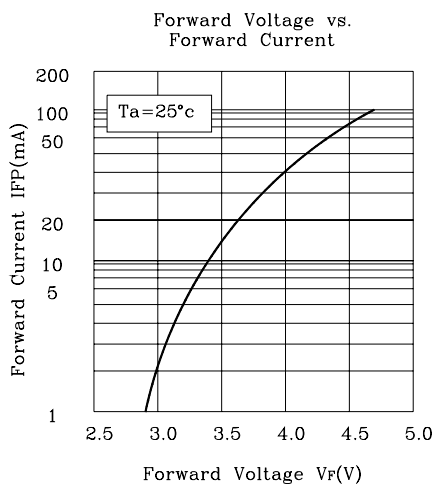

2.8×1.2×0.75mm SIDE VIEW LED WITH REFLECTOR

L-S715W

REV:A / 1

SHIPPING PACKAGE:

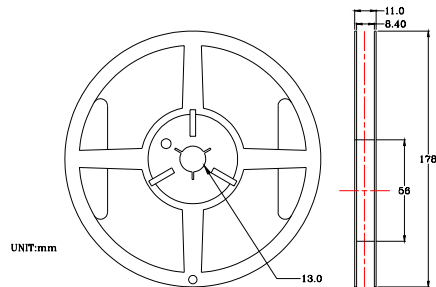

UNIT:mm

Processive direction

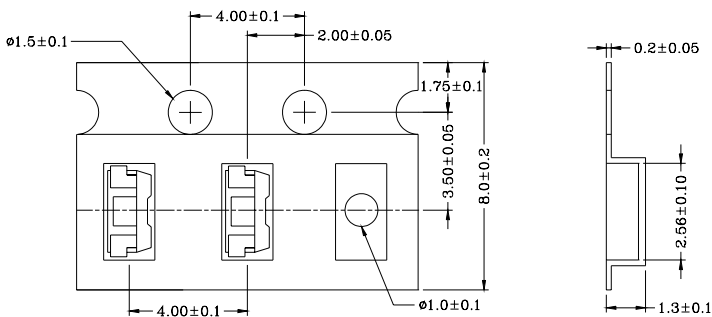
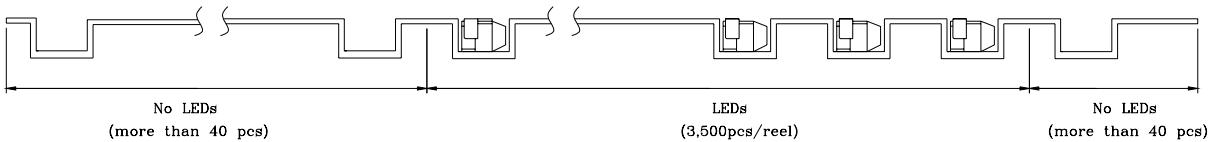
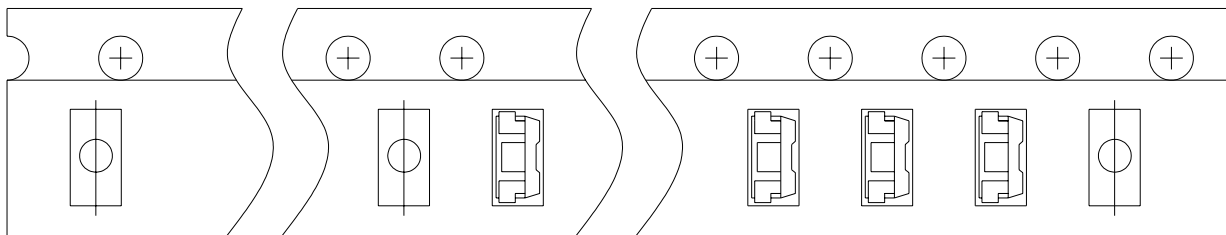

Loaded quantity per reel : 3500pcs/reel

2.8×1.2×0.75mm SIDE VIEW LED WITH REFLECTOR

L-S715W

REV:A / 1

SOLDERING CONDITIONS:

(1) Recommended Re-flow profile

Re-flow Profile

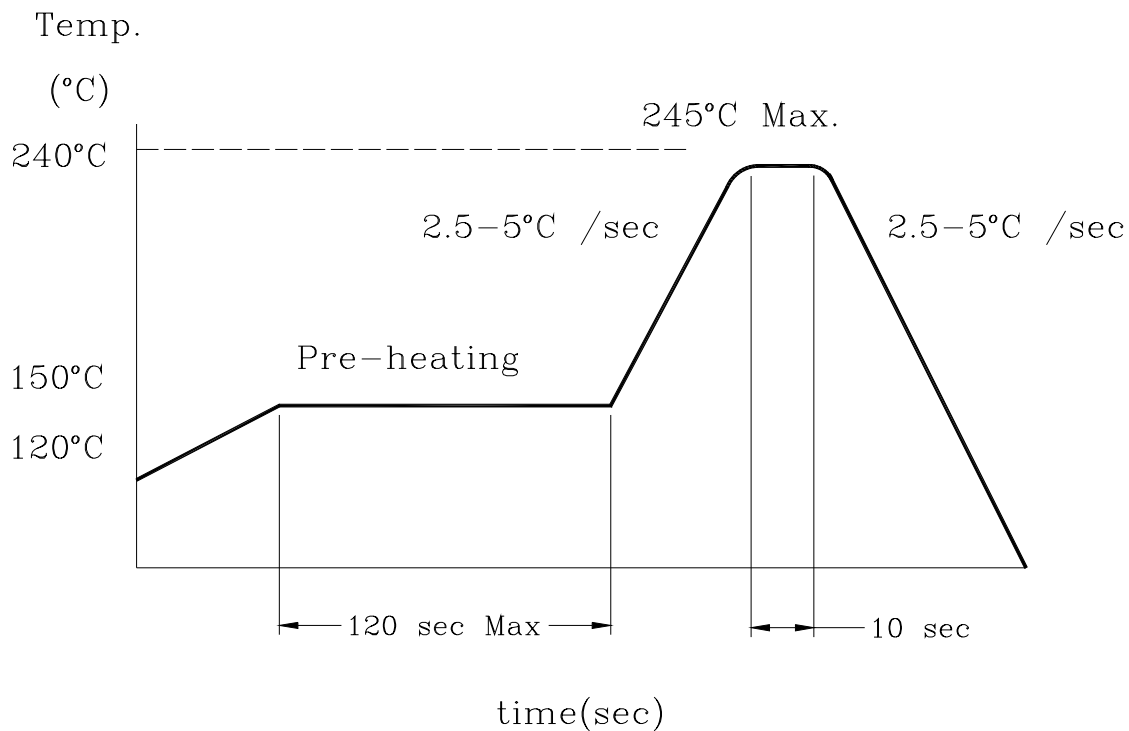

Recommended Soldering Pad

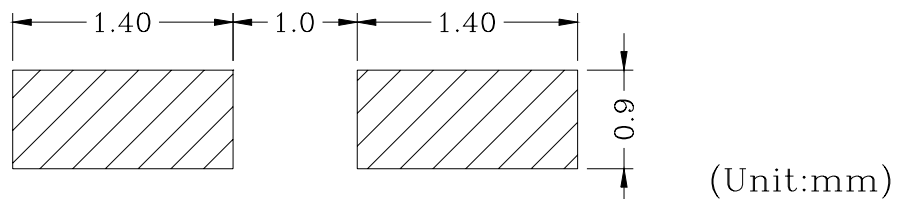

- (2) Re-flow soldering should not be done more than two times.
- (3) It is recommended that the user use the nitrogen reflow method.
- (4) When soldering, don't put stress on the LEDs during heating.
- (5) After soldering, don't warp the circuit board.
- (6) It is recommended that isopropyl alcohol (IPA) be used as a solvent for cleaning the LEDs.

2.8×1.2×0.75mm SIDE VIEW LED WITH REFLECTOR

L-S715W

REV:A / 1

TYPICAL ELECTRO-OPTICAL CHARACTERISTIC CURVES: Chromaticity Coordinates (CIE 1931 system)

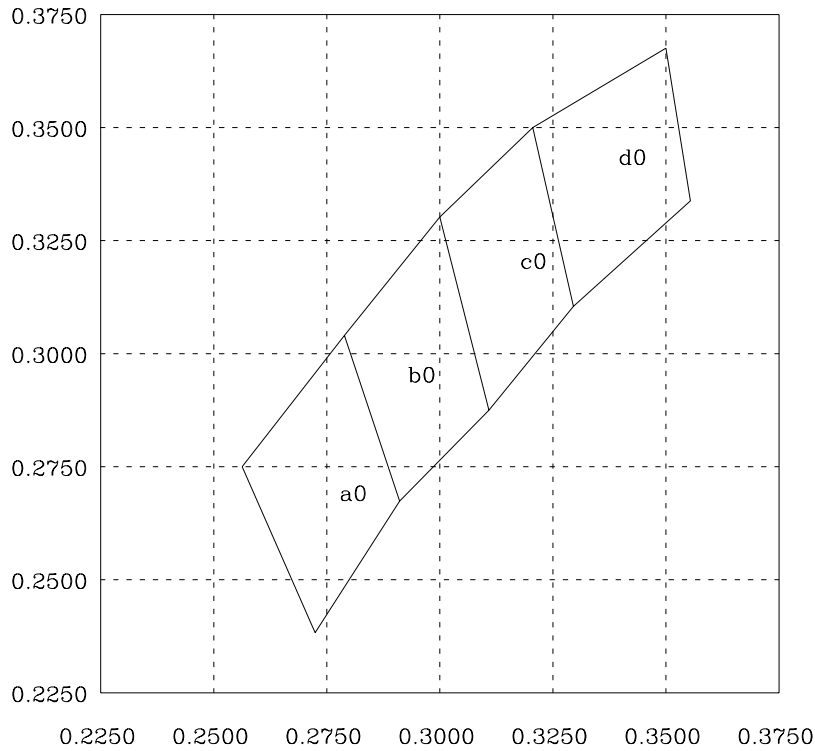

Ambient Temperature vs. Chromaticity Diagram

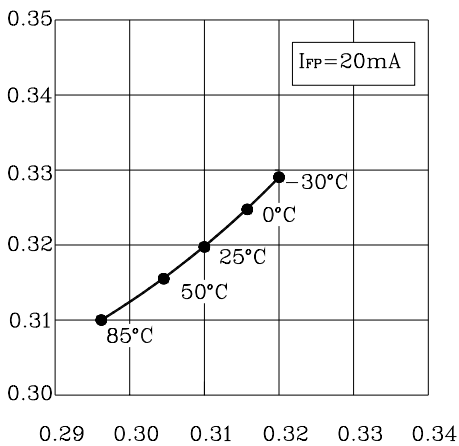

Radiation Characteristic(@ 25°C,20mA)

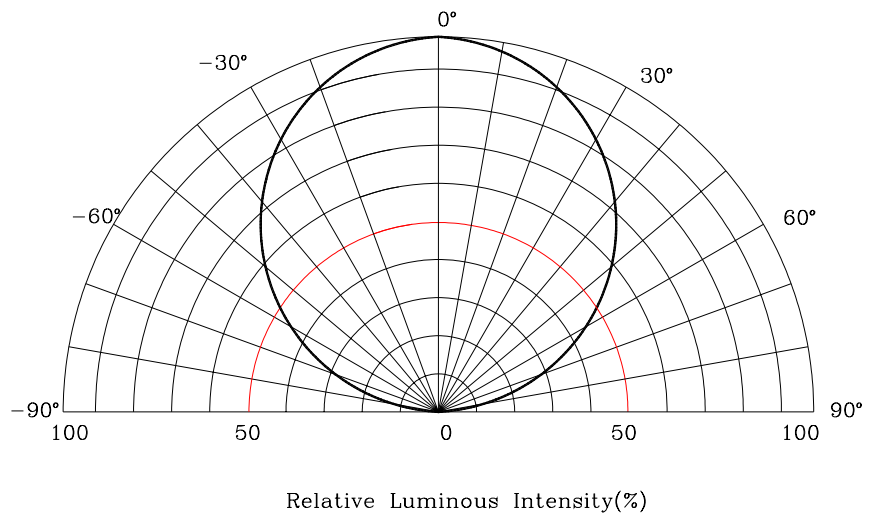

2.8×1.2×0.75mm SIDE VIEW LED WITH REFLECTOR

L-S715W

REV:A / 1

SHIPPINGPACKAGE:

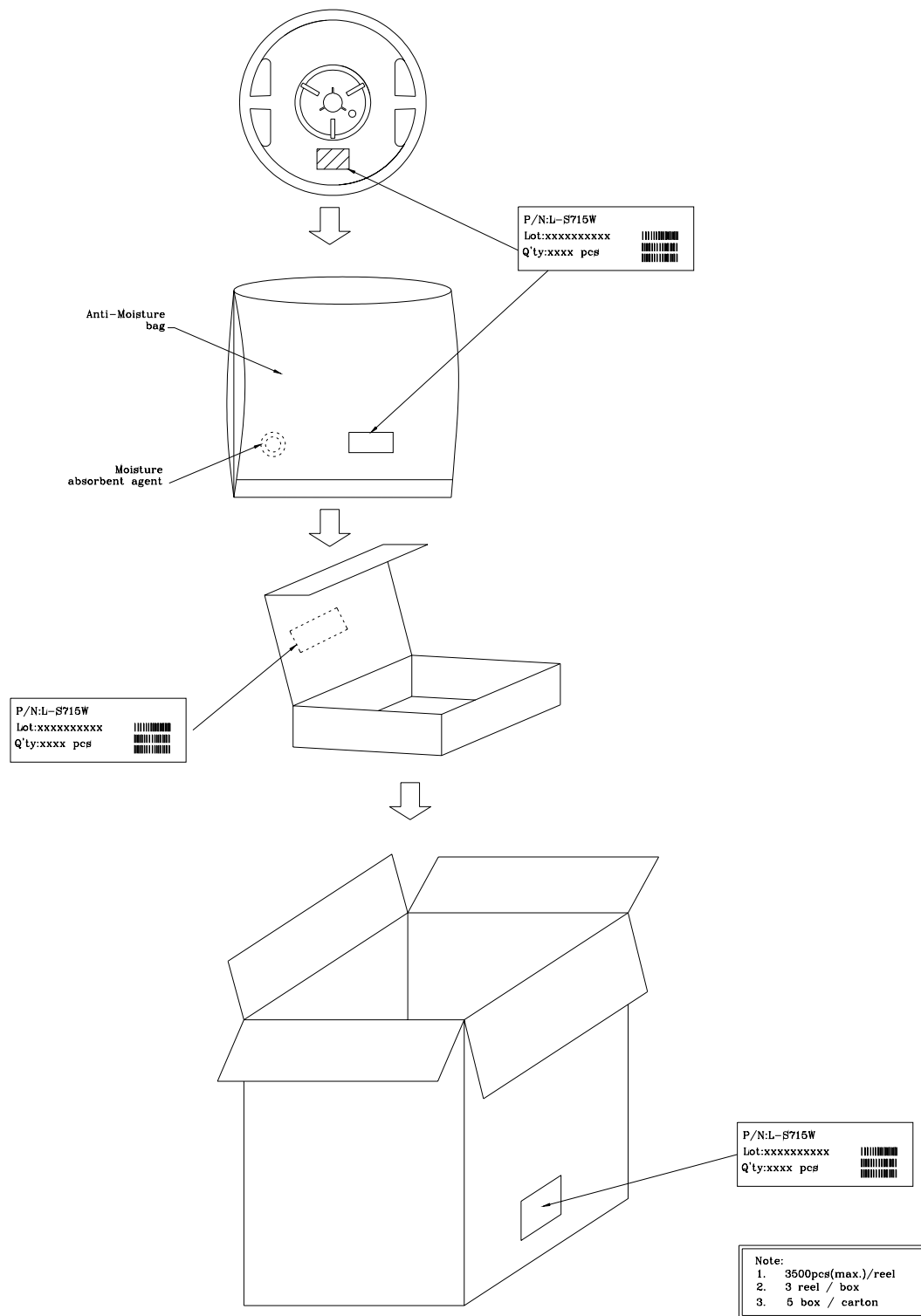

2.8×1.2×0.75mm SIDE VIEW LED WITH REFLECTOR

L-S715W

REV:A / 1

RELIABILITY PLAN:

The reliability of products shall be satisfied with items listed below.

Confidence Level:90%, LTPD:10%

No	Test Item	Description & Condition		Sample size	Ac/Re	Failure Criteria
1	Solderability	Tsld=245±5°C,10sec	1time	22	0/1	IV<L *0.6 (If:20mA) VF>U *1.1 (If:20mA) I _E >U *2.0 (V _R :5V) L:Lower Spec. Level U:Upper Spec. Level
2	Room Temperature operating	Ta=25°C If=20mA	1000hrs	22	0/1	
3	Room Temperature operating	Ta=25°C If=30mA	500hrs	22	0/1	
4	Low Temperature	Ta=-40°C	1000hrs	22	0/1	
5	High Temperature Storage	Ta=100°C	1000hrs	22	0/1	
6	Temperature Cycle	-40°C~25°C~100°C ~25°C 30min 5min 30min 5min	100 cycles	22	0/1	
7	High Humidity Heat	Ta=60°C RH=90% If=15mA	500hrs	22	0/1	

PART NO. SYSTEM

L S 7 1 5 W X X X X X X

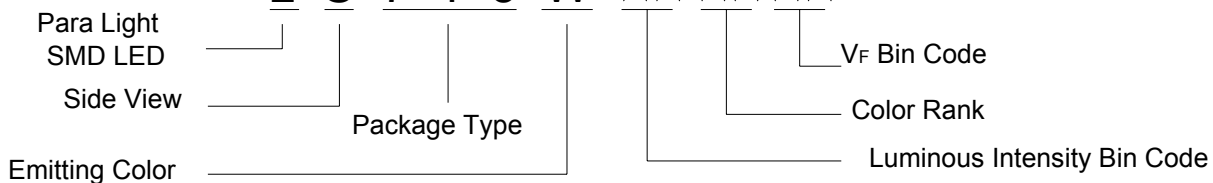

PART NO.	LED Type	Package Type	Emitting color
L	S	715	W
SMD LED	Side View	(L×W×H)= 2.8×1.2×0.75mm	White

2.8×1.2×0.75mm SIDE VIEW LED WITH REFLECTOR

L-S715W

REV:A / 1

CAUTIONS:

(1) Storage

- Before opening the package:

The LEDs should be kept at 30°C or less and 30%RH~85%RH. The LEDs should be used within a year. When storing the LEDs, moisture proof packaging with desiccant (Silica gel) is recommended.

- After opening the package:

The LEDs should be kept at 30°C or less and 30%RH~70%RH. The LEDs should be soldered within 168hours (7days) after opening the package. If unused LEDs remain, they should be stored in moisture proof packages, such as sealed containers with packages of moisture desiccant(Silica gel), or reseal the moisture proof bag again.

If the moisture desiccant (silica gel) has faded away or the LEDs have exceeded the storage time, baking treatment should be performed using the following conditions.

Baking treatment: more than 24hours at 65°C.

Please avoid conditions which may cause the LED to corrode, tarnish or discolor. This corrosion or discoloration might lower solder ability or might effect on optical characteristics.-Please avoid rapid transitions in ambient temperature ,especially in high humidity environments where condensation can occur.

- Moisture Proof package

When moisture is absorbed into the SMT package it may vaporize and expand during soldering. There is a possibility that this can cause exfoliation of the contacts and damage to the optical characteristics of the LEDs. For this reason, the moisture proof package is used to keep moisture to a minimum in the package. A package of a moisture desiccant (silica gel) is inserted into the moisture proof bag-The silica gel changes its color from blue to pink as it absorbs moisture.

(2) Static Electricity

- Static electricity or surge voltage damages the LEDs. It is recommended that a wrist band or an anti-electrostatic glove and shoe be used when handing the LEDs.

- All devices, equipment and machinery must be properly grounded. It is recommended that measures be taken against surge voltage to the equipment that mounts the LEDs.

When inspecting the final products in which LEDs were assembled, it is recommended to check whether the assembled LEDs are damaged by static electricity or not. It is easy to End static-damaged LEDs by a light-on test or a V_F test at a lower current (below 1 mA).

- Damaged LEDs will show some unusual characteristics such as the leak current remarkably increases, the forward voltage becomes lower, or the LEDs do not light at the low current. (Criteria: $V_F > 2.0V$ at $I_F = 0.5mA$).

(3) Heat Generation

- Please consider the heat generation of the LED when making the system design that it's very importance. The coefficient of temperature increase per input electric power is effected by the thermal resistance of the circuit board and density of LED placement on the board, and other components. It is necessary to avoid intense heat generation and operate within the maximum ratings given in this specification.

- The operating current should be decided after considering the ambient maximum temperature of LEDs.

2.8×1.2×0.75mm SIDE VIEW LED WITH REFLECTOR

L-S715W

REV:A / 1

(4) Others

- Care must be taken to ensure that the reverse voltage will not exceed the absolute maximum rating when using the LEDs with matrix drive.
- The LED light output is strong enough to injure human eyes. Precautions must be taken to prevent looking directly for more than a few seconds. Flashing lights have been known to prevent looking directly for more than a few seconds. Flashing lights have been known to cause discomfort in people ; you can prevent this by taking precautions during use. Also, people should be cautious when using equipment that has had LEDs incorporated into it.